



Create amazing spaces™

ITM. / ART. 17213340

ELEVATED GARDEN BED

ASSEMBLY INSTRUCTIONS | GUIDE DE MONTAGE | INSTRUCCIONES DE MONTAJE | MONTAGEANLEITUNG |
MONTAGE INSTRUCTIES | ISTRUZIONI DI MONTAGGIO | INSTRUÇÕES DE MONTAGEM

110 Kg
242 Lb



10 Kg
22 Lb

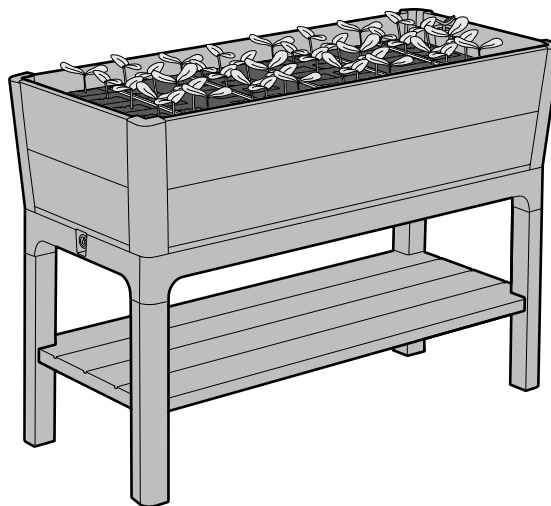

5025615

The Raised Patio Garden Bed is equipped with a water basin and gauge to make it easier for you to grow beautiful, healthy plants that have all the nourishment they need. All you need to do is keep an eye on the floating leaf. If the floating leaf sinks to its minimum height, you should wait several days and then water the plants. The precise number of days you wait depends on the type of plant and growing environment.

- If the red part of the floating leaf is visible, there is no need to water the plants.

Le bac de jardin surélevé est équipé d'un réservoir d'eau et d'une jauge pour vous aider à faire pousser des plantes belles et en bonne santé qui bénéficient de tous les éléments nutritifs dont elles ont besoin. Il vous suffit de surveiller le flotteur en forme de feuille. Si le flotteur atteint son niveau minimum, veuillez attendre quelques jours et arroser les plantes. Le nombre précis de jours d'attente dépend du type de plantes et de leur milieu de culture.

- Si la partie rouge du flotteur est visible, les plantes n'ont pas besoin d'être arrosées.

El Parterre Elevado para Terraza está equipado con un depósito de agua y un medidor para que le resulte más fácil cultivar plantas sanas y bonitas que dispongan de todos los nutrientes que necesitan. Solo necesitará vigilar la hoja flotante. Si la hoja flotante se hunde hasta su altura mínima, entonces se debe esperar unos días para regar las plantas. El número exacto de días que se debe esperar dependerá del tipo de planta y del entorno de cultivo.

- Si se puede ver la parte roja de la hoja flotante, no hace falta regar las plantas.

Das Hochbeet für die Terrasse ist mit einem Wasserbecken und einer Wasserwaage ausgestattet, damit Sie schöne, gesunde Pflanzen züchten können, die alle Nährstoffe haben, die sie brauchen. Sie müssen nur das Schwimmblatt im Auge behalten. Wenn das Schwimmblatt auf seine Mindesthöhe sinkt, sollten Sie mehrere Tage warten und die Pflanzen dann gießen. Die genaue Anzahl der Tage, die Sie warten, hängt von der Pflanzenart und der Wachstumsumgebung ab.

- Wenn der rote Teil des Schwimmblatts sichtbar ist, müssen die Pflanzen nicht gegossen werden.

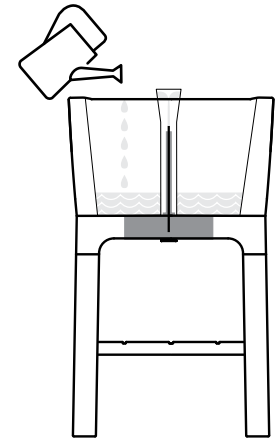

De verhoogde bloembak voor terras is voorzien van een waterbassin en watermeter om het voor u gemakkelijker te maken om mooie, gezonde planten te kweken, die alle voeding krijgen die zij nodig hebben. U hoeft alleen op de vlotter te letten. Als de vlotter naar de minimale hoogte zakt, moet u enkele dagen wachten om dan de planten water geven. Het exacte aantal dagen dat u moet wachten is afhankelijk van het type plant en de groeiomgeving.

-Als het rode gedeelte van de vlotter zichtbaar is, hebben de planten geen water nodig.

L'aiuola a prode rialzate per i cortili è dotata di una bacinella per l'acqua con misuratore che consente di coltivare bellissime piante sane con tutto il nutrimento necessario per le loro esigenze. Tutto ciò che serve è prestare attenzione al sistema galleggiante: se raggiunge la sua altezza minima, bisognerà attendere diversi giorni prima di annaffiare le piante. Il numero esatto di giorni dipenderà dal tipo di pianta e dall'ambiente di crescita.

-Se è visibile la parte rossa del sistema galleggiante, non sarà necessario annaffiare le piante.

O canteiro elevado para pátio está equipado com um reservatório de água e um medidor para facilitar o cultivo de plantas bonitas e saudáveis, com todos os nutrientes de que necessitam. Tudo o que precisa de fazer é ficar de olho na folha flutuante. Se a folha flutuante atingir a altura mínima, aguarde vários dias e depois regue as plantas. O número exato de dias que espera depende do tipo de planta e do ambiente de cultivo.

- Se a parte vermelha da folha flutuante for visível, não há necessidade de regar as plantas.

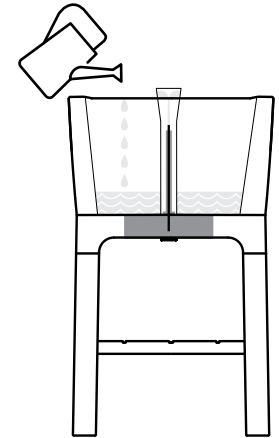

- It is recommended to occasionally pull out the drainage cap in order to drain excess water and keep the roots healthy.
- It is often a good idea to recycle drainage water from the Raised Patio Garden Bed by using it to water other plants, as it is rich in natural salts and minerals. This helps to conserve water and contribute to a more environmentally-friendly garden.

• Nous vous recommandons de retirer le bouchon de drainage de temps en temps, afin d'évacuer l'excès d'eau et de préserver la santé des racines.
• Nous vous recommandons également de recycler l'eau drainée du bac de jardin et de l'utiliser pour arroser d'autres plantes, car c'est une eau riche en sels et en minéraux naturels. Ainsi, vous réduirez la consommation d'eau et contribuerez à la réalisation d'un jardin plus écologique.

- Se recomienda extraer el tapón de drenaje de vez en cuando para drenar el exceso de agua y mantener las raíces sanas.
- A menudo, resulta una buena idea reciclar el agua drenada del arriate para regar otras plantas, ya que es rica en sales y minerales naturales. Esto ayuda a ahorrar agua y a tener un jardín más respetuoso con el medio ambiente.

• Es wird empfohlen, die Drainagekappe gelegentlich herauszuziehen, um überschüssiges Wasser abzulassen und die Wurzeln gesund zu halten.
• Es ist oft eine gute Idee, das Drainagewasser aus dem Hochbeet wiederzuverwenden und es zum Gießen anderer Pflanzen zu verwenden, da es reich an natürlichen Salzen und Mineralien ist. Dies hilft, Wasser zu sparen und trägt zu einem umweltfreundlicheren Garten bei.

- Het wordt aangeraden om af en toe de drainagedop te verwijderen om overtollig water af te voeren en de wortels gezond te houden.
- Het is vaak een goed idee om het drainagewater van de verhoogde bloembak te recyclen voor het bewateren van andere planten. Het is namelijk rijk aan natuurlijke zouten en mineralen. Dit helpt water te besparen en draagt bij aan een tuin die milieuvriendelijker is.

Si consiglia di rimuovere il tappo di scarico di tanto in tanto, in modo da lasciar drenare l'acqua in eccesso e tenere le radici in salute.

• È ottima l'idea di riciclare l'acqua di drenaggio dell'aiuola a prode rialzate per i cortili per annaffiare altre piante, essendo ricca di sali naturali e minerali. Questo aiuta a conservare l'acqua e ottenere un giardino più ecocompatibile.

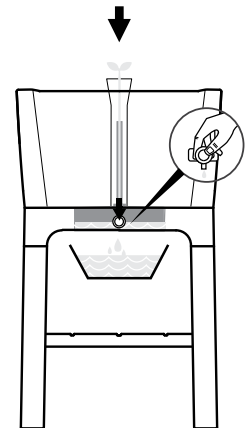
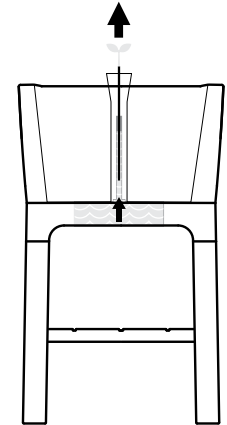

Recomenda-se retirar ocasionalmente a tampa de drenagem para drenar o excesso de água e manter as raízes saudáveis.

- É muitas vezes uma ideia inteligente reciclar a água de drenagem do canteiro elevado do jardim do pátio, utilizando-a para regar outras plantas, uma vez que é rica em sais e minerais naturais. Isto ajuda a poupar água e contribui para uma vida mais jardim amigo do ambiente.

The product's structure allows continuous water drainage and is therefore appropriate for external use only.

La structure du produit permet un drainage continu de l'eau et est par conséquent uniquement adaptée à un usage extérieur.

La estructura del producto permite un drenaje continuo del agua, por lo que es recomendable utilizarlo solo en exteriores.

Die Produktstruktur ermöglicht einen kontinuierlichen Wasserablauf und ist daher nur für die Anwendung im Außenbereich (im Freien) geeignet.



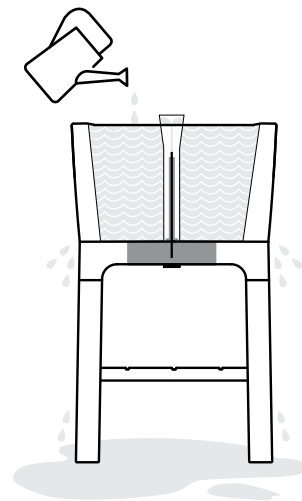

De structuur van het product zorgt voor een continue waterafvoer en is daarom uitsluitend geschikt voor gebruik buitenshuis.

La struttura del prodotto consente un drenaggio continuo dell'acqua, limitandone l'uso esclusivamente agli spazi esterni.

A estrutura do produto permite o escoamento continuo da água, sendo por isso apenas adequado para utilização no exterior.

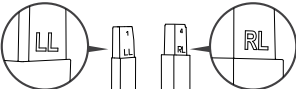
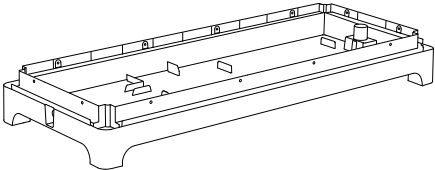
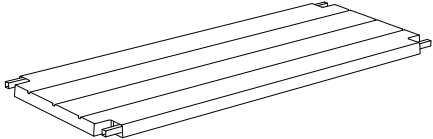
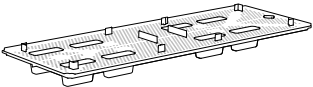

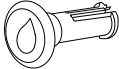
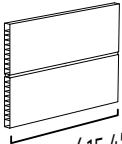
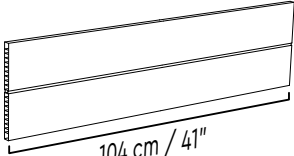
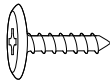
ASSEMBLY PARTS | PIÈCES À ASSEMBLER | PIEZAS DE ENSAMBLE | MONTAGETEILE | ONDERDELEN | PARTI DA MONTA RE | PEÇAS DE MONTAGEM

 <p>LL (x2) RL (x2)</p>	 <p>M (x1)</p>	 <p>S (x1)</p>	
 <p>F (x1)</p>	 <p>P (x4)</p>	 <p>C (x4)</p>	 <p>(x1)</p>
 <p>A (x2) 39 cm / 15.4"</p>	 <p>B (x2) 104 cm / 41"</p>	 <p>X (32+2)</p>	 <p>WG (x1)</p>

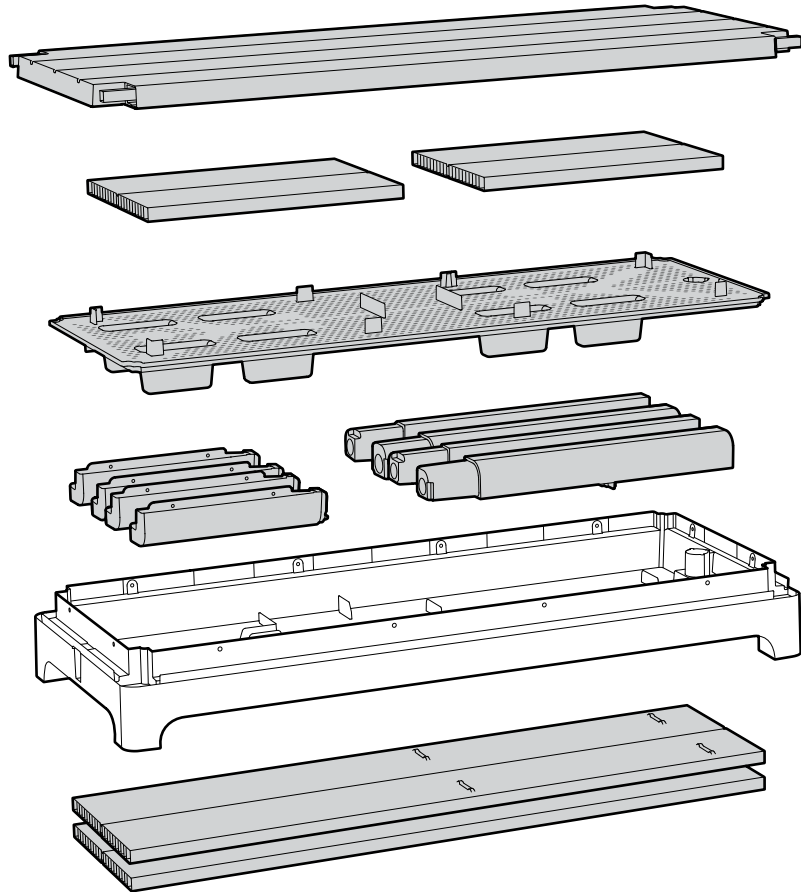

1

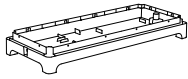

M (x1)



LL (x1)



RL (x1)

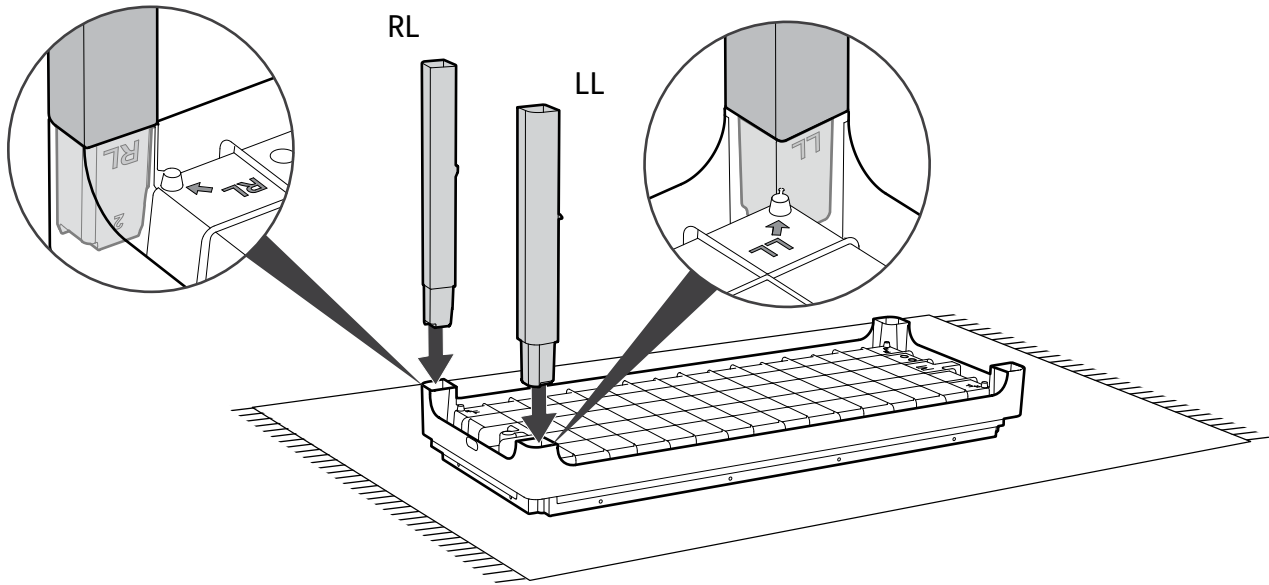

2



S (x1)



LL (x1)



RL (x1)

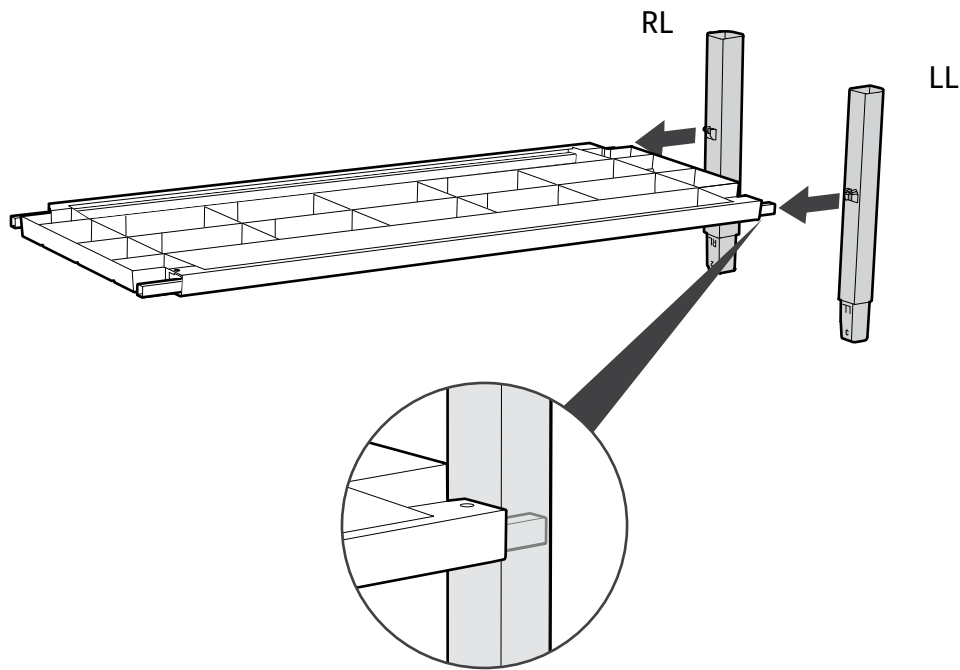

3

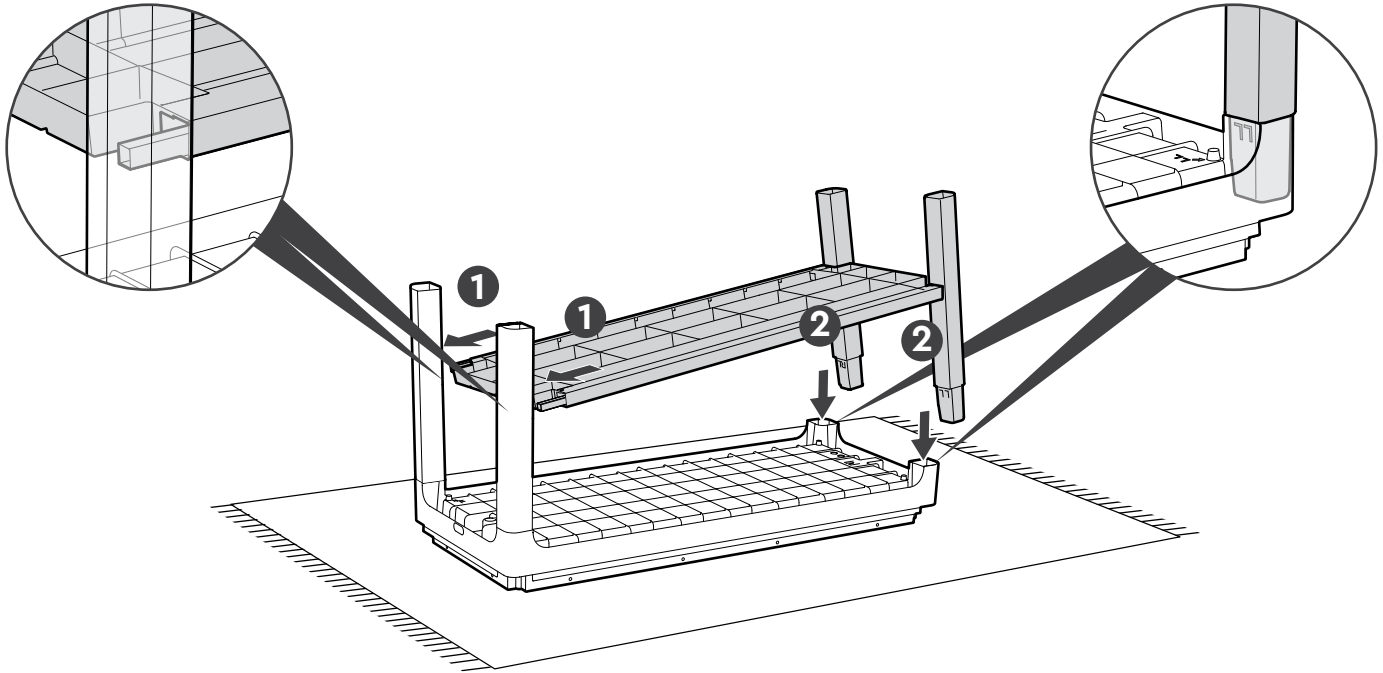

4

 (x4)

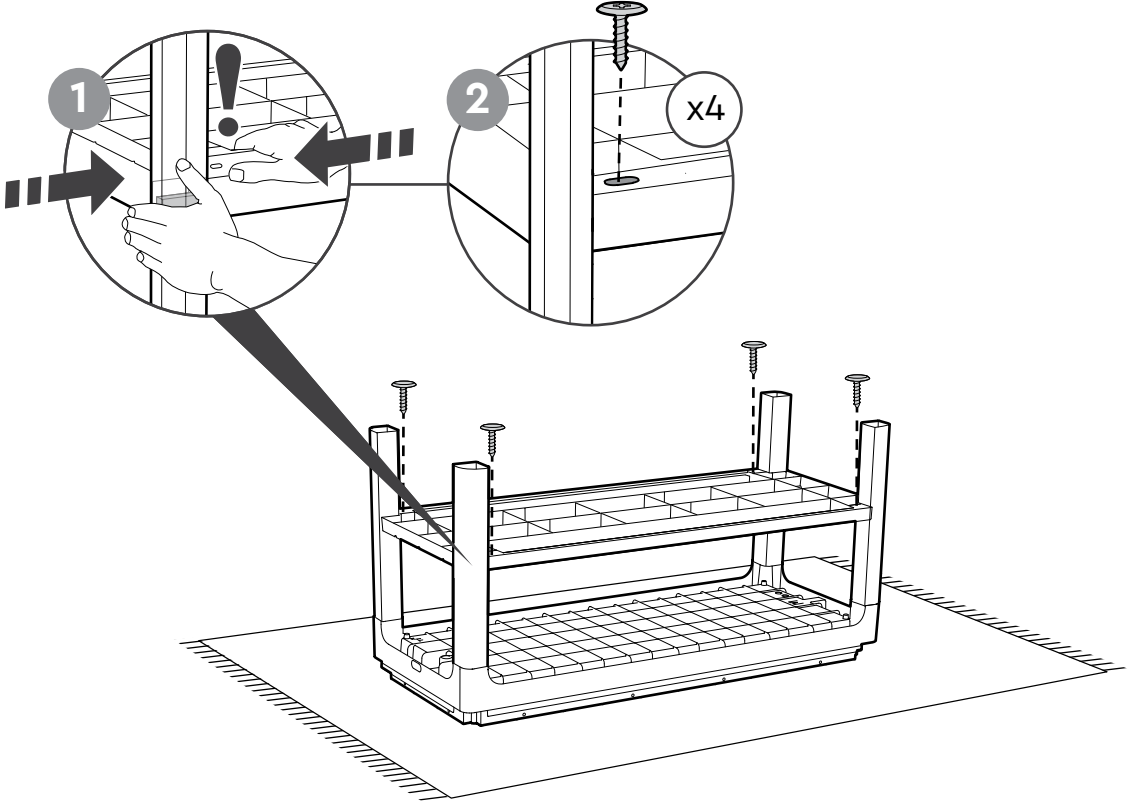

5



P (x4)

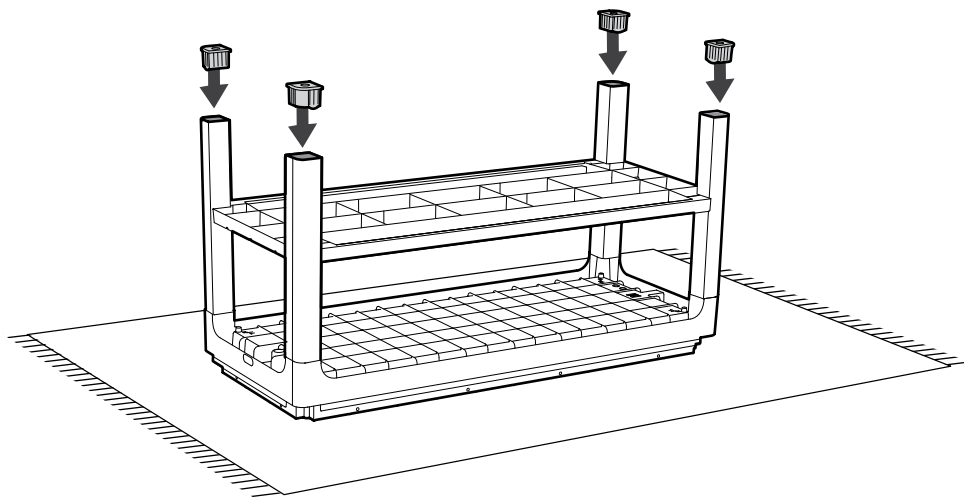

6

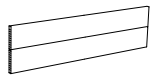

B (x2)



C (x4)

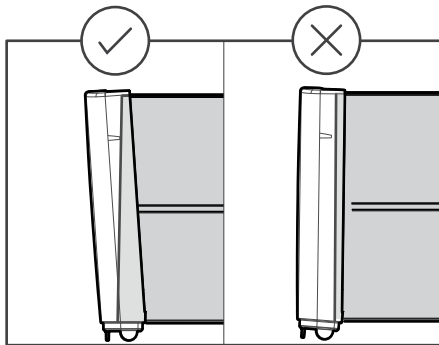

x2

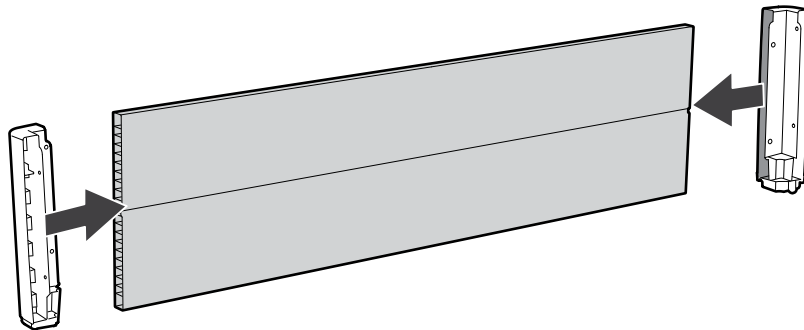

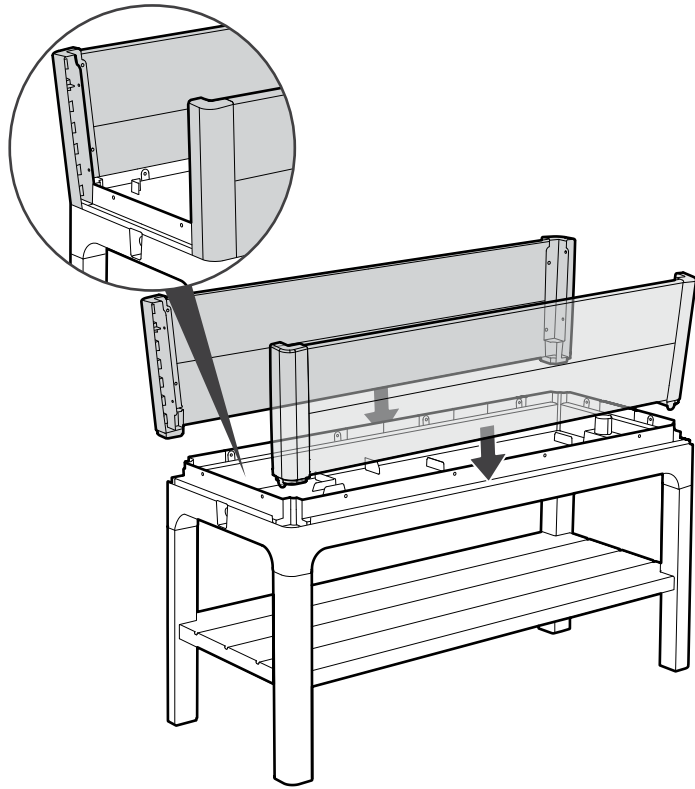



8

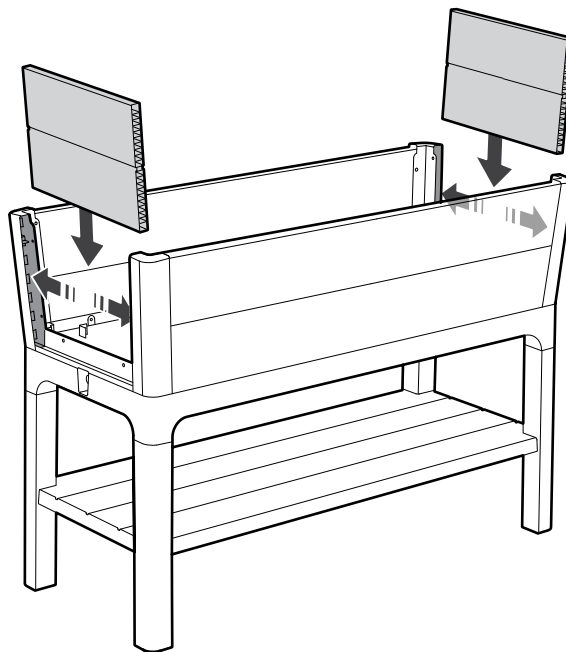
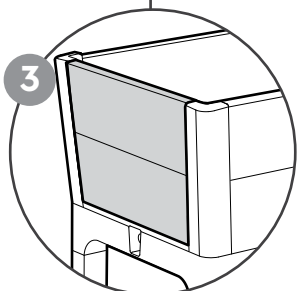
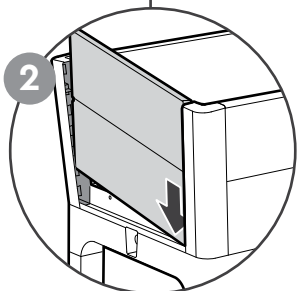
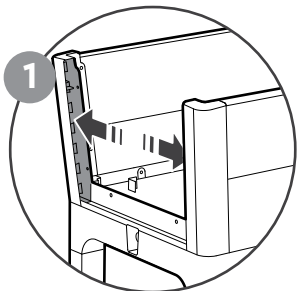

A (x2)



9

 (x8)

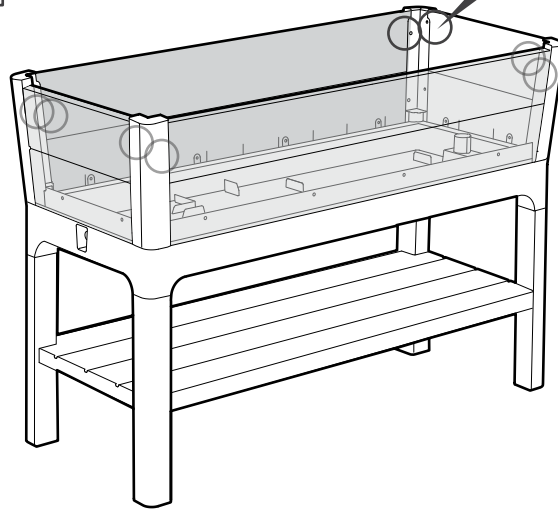
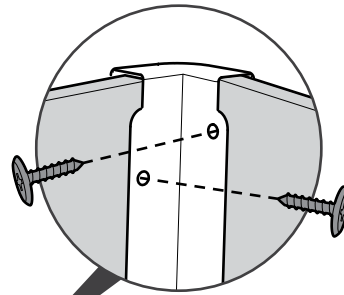
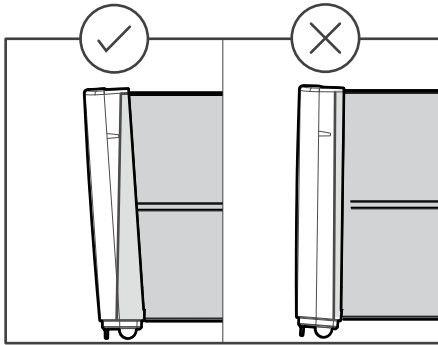

10

 (x8)

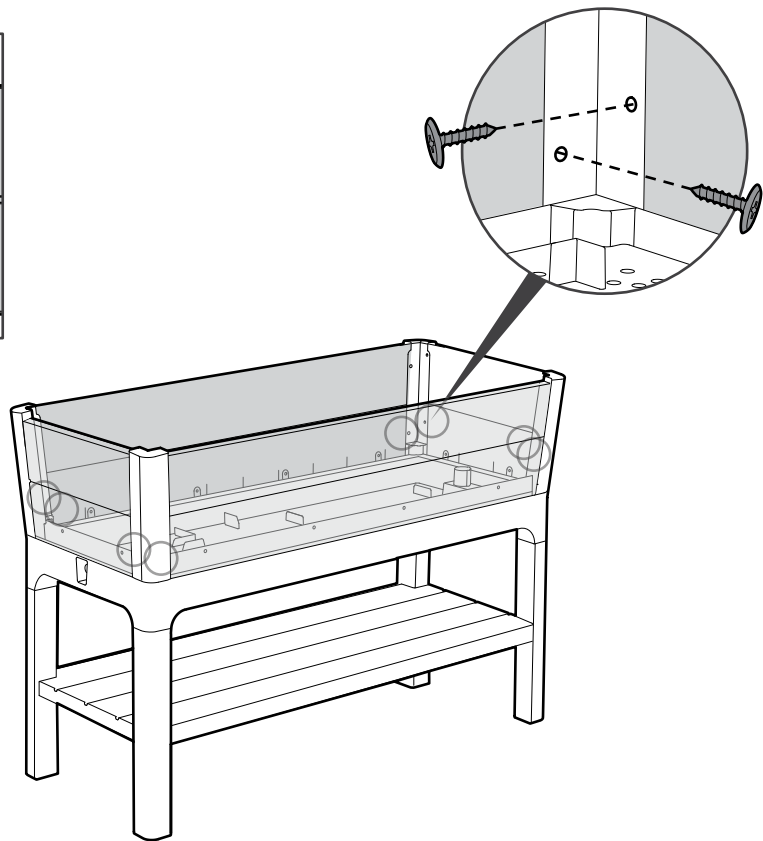
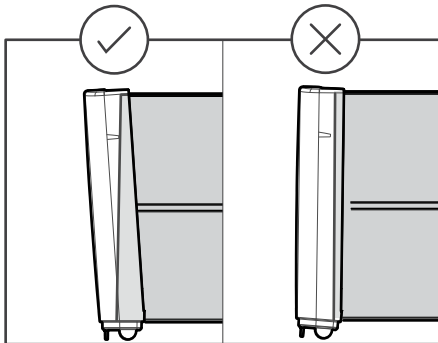
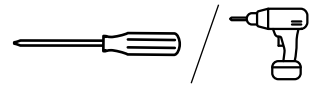

11



(x12)

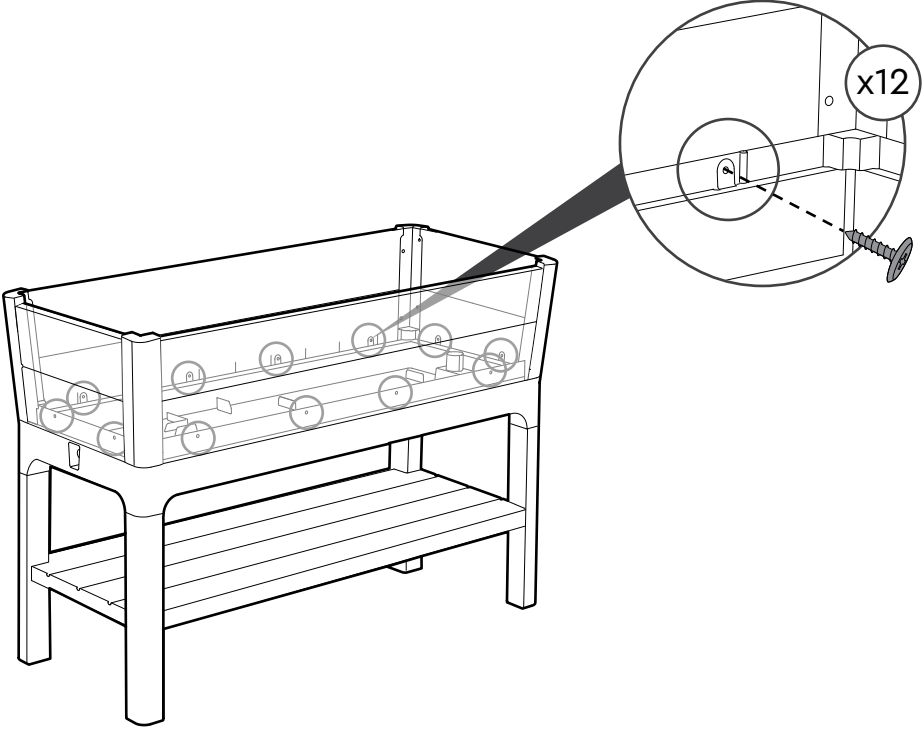

12

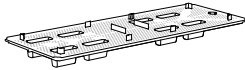

F (x1)

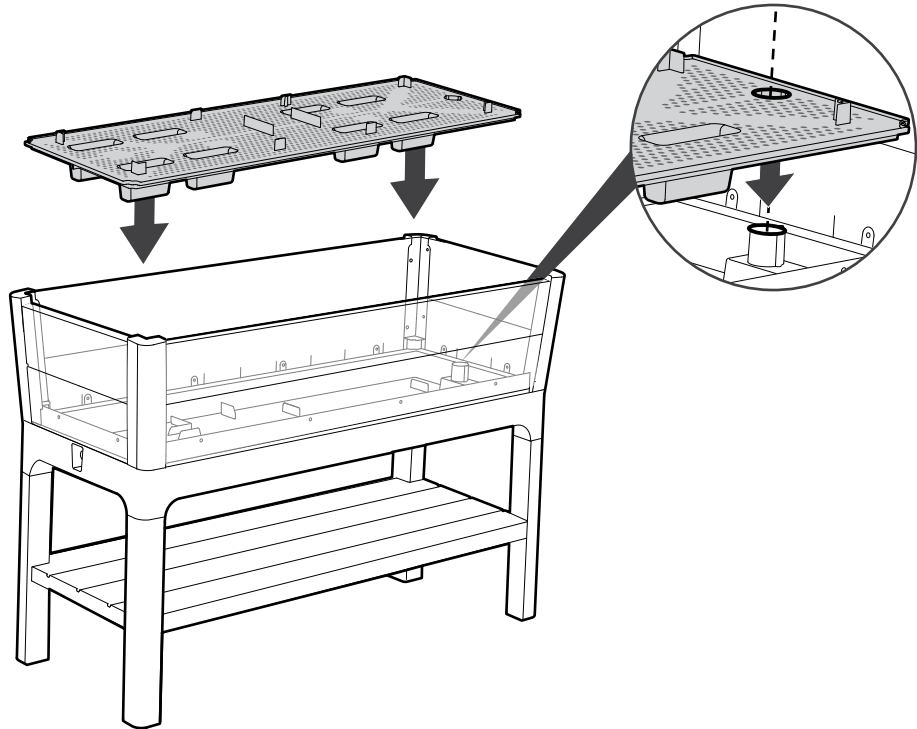

13



WG (x1)

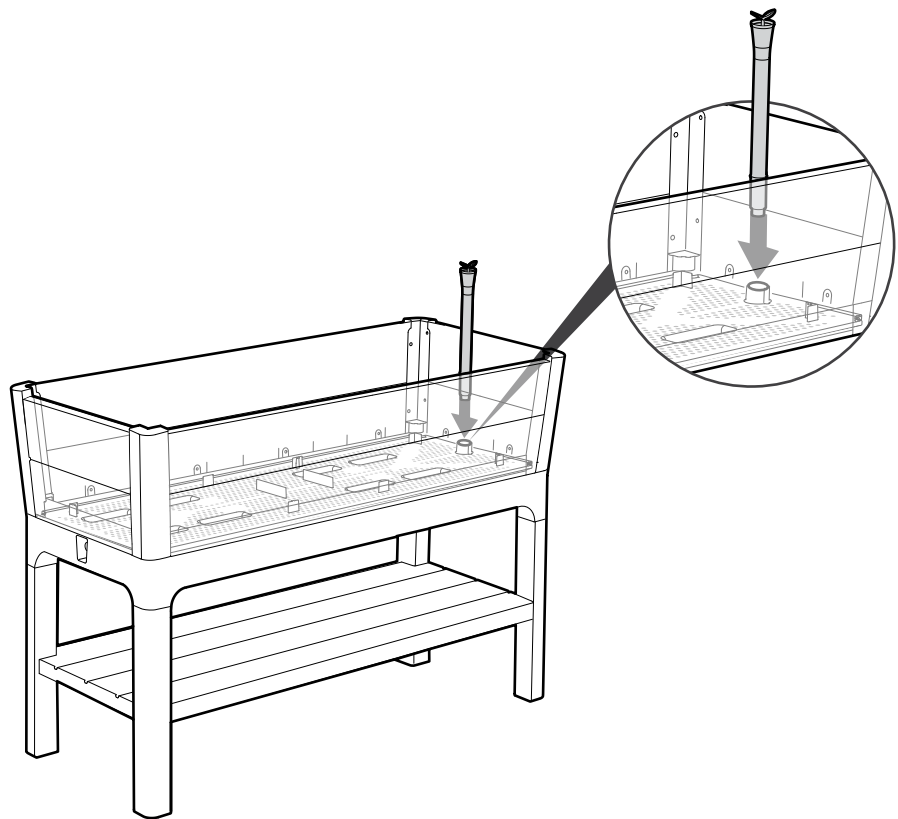

14

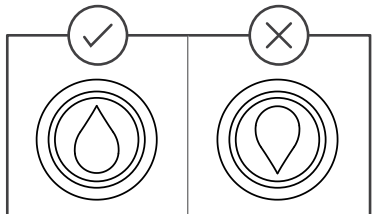
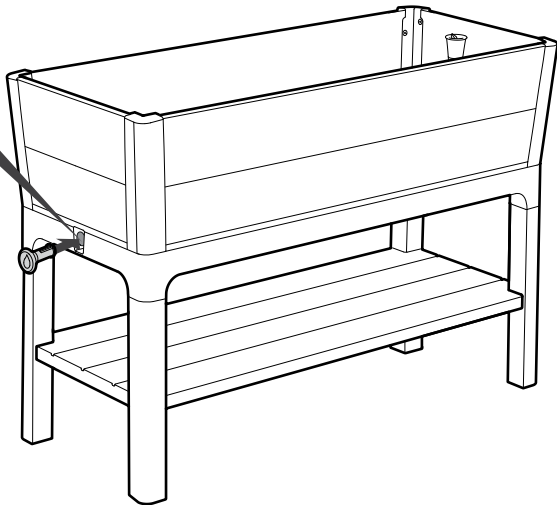
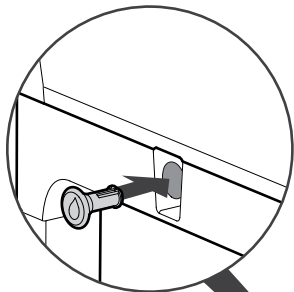
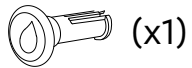



For any assistance, please contact customer service.

Pour toute assistance, veuillez communiquer avec notre service à la clientèle. | **Para solicitar ayuda por favor, póngase en contacto con nuestro servicio al cliente** | Bitte kontaktieren Sie unseren Kundenservice, falls Sie Hilfe benötigen | **Voor ondersteuning, gaarne contact opnemen met onze klantendienst** | Per qualsiasi tipo di assistenza, potete contattare il nostro servizio clienti | **Para obter assistência, favor contatar nosso atendimento ao cliente em.**

WWW.KETER.COM

US / Canada: (EN/FR)

Tel: +1-888-374-4262
keter.com/en-us/contact-us.html
Email: NACS@keter.com

UK: (EN)

Tel: +44-121-506-0008
Email: CSUK@keter.com
Keter UK Ltd
16 Great Queen Street, Covent
Garden, London, WC2B 5AH
Mon - Fri | 8am - 4pm

Israel:

Tel: 1-700-70-6015

Switzerland:

Tel: +41-62-767-00-50
Email: info@neogard.ch

France:

Votre produit ayant été acheté dans
une enseigne, qu'elle soit physique ou
sur internet, c'est auprès de cette
enseigne que vous devez faire votre
demande SAV.

Australia:

Tel: 03 9544 6999
Email: keteraus@keter.com
28 Buckland St,
Clayton, Victoria 3168
Mon - Fri | 9am - 5pm

Iberia:

Email: spvketer@carcaba.com

South Africa:

Email: info@keter.co.za

Spain: (SP)

Tel: +34-876-14-13-93
www.keter.com/es-es/contact-us.html
E-mail: Service.Iberia@keter.com
Mon - Fri | 8am - 5pm

Italy:

Tel: +39 0422 745900
Email: Servizio.clienti@keter.com

고객센터:

Tel: 031-767-2492
Email: info@keter.co.kr
월 - 금 | 9:00am - 05:30pm

Poland:

Tel: +48 59 84 19 892
Email: Service.poland@keter.com

Hungary:

Tel: +36 52 565 920
Email: Service.hungary@keter.com

Nordics:

Tel: +48 59 84 19 892
Email: Service.nordic@keter.com

Germany/Austria:

Tel: +49 (3) 222-10-96-42-1
Email: service@keter-ersatzteile.de

NL/BE/LUX:

Email: Klantenservice@keter.com

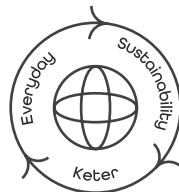

KETER[®]

Le développement durable au
quotidien | Sostenibilidad día a día



Designed to Last | Conçu pour durer | Diseñado
para durar | Auf Langlebigkeit ausgelegt |
Duurzaam ontworpen | Progettato per durare |
Projetado para durar



Recyclability & Recycling | Recyclabilité et
recyclage | Reciclabilidad y reciclable | recyclefähig
& recycelt | Recyclebaarheid & recycling |
Riciclabilità e Riciclo | Reciclabilidade e Reciclagem



Community | Communauté |
Comunidad | Community |
Community | Comunità | Comunidade



Responsible Manufacturing | Fabrication responsable |
Producción responsable | Verantwortungsbewusste
Herstellung | Verantwoorde productie |
Produzione responsabile | Fabricação responsável

Made in Israel by | Fabriqué en Israël par | Hecho en Israel por | Hergestellt in Israel von | Gemaakt in Israël door
| Realizzato in Israele da | Fabricado em Israel por Keter Home and Garden Products Ltd., 1 Sapir St. Industrial
Area, Herzliya 4685205, Israel



<https://www.fairnemoedechets.fr>

5025615